

SELECT PRO BOLT ON LATCH



SPECIFICATION SHEET

SBL

- Stainless steel latchbolt springs 13mm (1/2") into the gate post to hold the gate closed.
- Latchbolt is adjustable in length for precise fitting on site. Easy to rotate for Left handed and Right handed gates.
- Supplied with handles – three styles available.
- Supplied with bolt support plate and gate post strike plate.



PRODUCT DETAILS

Product code:	Description:
SBL1601	To fit flat bar and up to 30mm box section (1/2" - 1-1/4")
SBL1602	To fit 40 to 60mm box section (1-1/2" - 2-1/4")

Style of handle:	Description:
TDH	Traditional handle set
OK	Octagonal handle set
AH	Black lever handle set

Marine grade: Salt spray tested for 1000 hours.
 Latchbolts: Adjustable, latchbolt springs 13mm (1/2").

Perfect for both LH/RH gates.



INSTALLATION

- Drill 2 x 9mm (3/8") dia. holes at 92mm (3-5/8") centres for M8 fixing bolt.
- Drill 18mm (3/4") clearance hole for latchbolt at 22mm (7/8") centres down from the top 9mm (3/8") hole.
- Fix lock in place using stainless steel clamp plate, bolt support plate and 2 stainless steel countersunk fixing bolts supplied.
- Drill clearance hole in keep or outer frame to receive the latchbolt. Slot this hole vertically to allow for gate sag. Fit strike plate by either welding or screw fixing it to the gate post.
- Ensure latchbolt moves freely without binding on gate or frame.
- MAINTENANCE** Every two months, lubricate the latchbolt with light oil. Annually, dismantle lock and spray the mechanism inside with light oil.

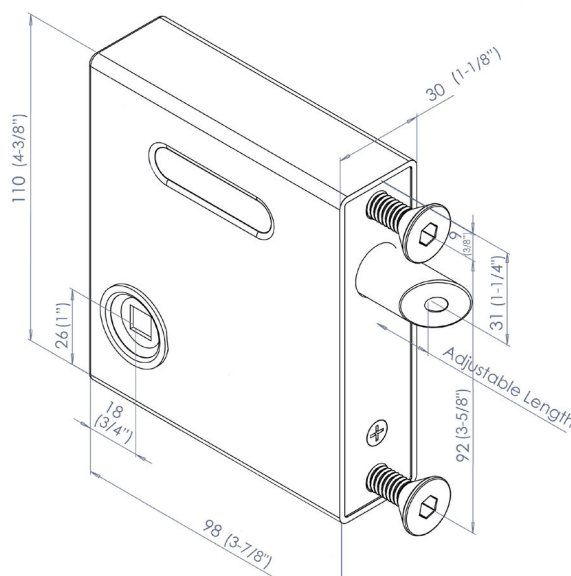

Check out our Gatemaster Locks channel to view installation videos!

GATEMASTER

VISIT GATEMASTERLOCKS.COM FOR MORE INFORMATION

